



CHURCH HALL

**179 Pixmore Way
Letchworth Garden City
Herts
SG6 1QT
tel 01462-637373**

HANDBOOK FOR HIRERS INCLUDING RULES & REGULATIONS & CONDITIONS OF HIRE

**Booking Secretary:
Vicky Cameron – tel 01462 637373
Monday to Friday – 9.15am to 1.15pm**

**Emergency out of hours contact
Tel 07941 376316
or 07720 246436**

Sept 2020

FACILITIES

MAIN HALL – 16.8 m x 9.7 m

A shuttered serving hatch opens on to the main hall. **The stage area is strictly out of bounds other than for scheduled performances agreed with St Paul's PCC.**

UPPER HALL – 9.2 m x 6.08 m

There is a toilet and washbasin cubicle and also a large sink, off the upper hall. There is also a smaller room, set out as a lounge suitable for a static group of 10-12 persons, off the side.

KITCHEN – 9.2 m x 3.05 m

A shuttered serving hatch opens on to the main hall.

There are facilities for the preparation of hot food.

The kitchen is equipped with a double sink with constant hot water, hand basin, ample electric sockets, a small fridge (but no freezer), gas cooker, microwave, dishwasher, water boiler for hot drinks, warming cupboard and insect killer.

TOILETS

Men's toilets are located to right of front entrance lobby. Ladies' toilets are through the double swing doors to left – near the stage. A toilet for the disabled, with baby change is located adjacent to the Ladies' toilet.

CAPACITY

Main Hall - The maximum number for events is 150

Upper Hall - The maximum number for events is 40

FURNITURE AND EQUIPMENT – Main Hall

23 tables (21 of which are 68.5cm x 122cm, the other 2 are larger)

72 chairs in hall (these should be in stacks of 6)

29 additional chairs available if necessary

2 chair trolleys

80 mugs in kitchen for general use

FURNITURE AND EQUIPMENT – Upper Hall

6 tables (68.5cm x 122cm)

26 chairs in hall

20 mugs and a kettle for general use

Please note the entire premises are non-smoking

Floor Plan – not to scale

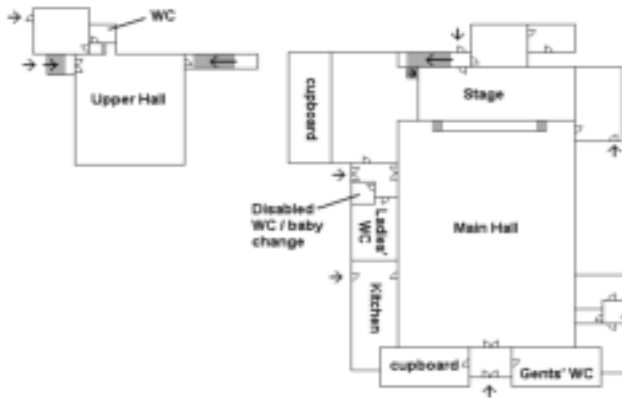

The information on the following pages cover the conditions on which hire is made

SIGNATURE TO A HIRING AGREEMENT COMMITTS THE HIRER TO THEIR OBSERVANCE

Hirers should therefore read this information carefully and consult the Booking Secretary if there are any doubts as to the meaning of any items

For the purposes of these conditions, the term HIRER shall mean an individual Hirer or, where the Hirer is an organisation, the authorised representative

ST PAUL'S CHURCH HALL
STANDARD CONDITIONS OF HIRE

1. Bookings, Deposits and Confirmations

- a) Bookings may be made up to 12 months in advance but must be confirmed and deposits paid at least 3 months before the date of the event.
- b) A booking deposit of 25% is applicable on all bookings where the hire cost is greater than £30. Bookings costing less than £30 will be required to be paid in full.
- c) Final balances and damage deposits must be paid at least 2 weeks before the hire date.
- d) Dependant on the nature of hire a damage deposit of either £100 or £150 will be required. This will be returned to hirers in the week following their hire once all facilities have been checked.
- e) Booking times must be strictly adhered to. Functions taking place Monday to Saturday must finish by **11.00 pm** and the hall vacated by **11.30 pm**. Sunday functions must be vacated by 10.00 pm.
- f) THE HIRER should include time needed for preparation and clearing up in establishing the total time of hire required. Access to the hall will not be allowed outside the booked time. The Hirer is responsible for making sure that the premises are not left unattended and unsecured at any time during or at the end of the hire period. Entry is only permitted to areas booked. Access to other areas is not allowed.
- g) St Paul's Church Letchworth PCC reserves the right to cancel the *Hiring Agreement* at any time, or prohibit the continuance of an event, if it considers that THE HIRER has failed to comply with any of the conditions of hire, or that continuance of the event is undesirable. In such circumstances, the Hirer shall forfeit the whole of the fees paid for the hire, and St Paul's Church Letchworth PCC shall not be liable for any payment in respect of any actual or presumed loss of profit or for any other cause.

- h) St Paul's Church Letchworth PCC reserves the right to make alterations to any of the Conditions of Hire, and charges of hire and related to the hire from time to time and at its own discretion.

2. Cancellations

- a) In the event of a cancellation before the balance is paid the part payment will be forfeited. After this point the whole amount will be forfeited.
- b) The church hall facilities are primarily for the benefit of the Community and the church. Our church program does change and we may have to cancel or curtail bookings. Where possible we will give 3 months notice to hirers.

3. Liability

- a) THE HIRER will be fully responsible for all persons and property brought onto the premises during the period of hire and will indemnify St Paul's Church Letchworth PCC against any claims in respect of loss, injury, or damage sustained by or to such persons or property other than claims in respect of death or personal injury or loss of property arising solely from the negligence of St Paul's Church Letchworth PCC, its servants or agents.
- b) If hiring on behalf of a group or organisation it is the responsibility of THE HIRER to ensure that if they are not present at a hiring, that whoever is responsible on that day is aware of the 'Conditions of Hire'.
- c) THE HIRER shall be responsible for obtaining such licences as may be needed.
- d) In the event of the Hall or any part thereof being rendered unfit for the use for which it has been hired, St Paul's Church Letchworth PCC shall not be liable to the Hirer for any resulting loss or damage whatsoever.
- e) All Hirers must ensure that a mobile phone is available for use in emergencies.

4. Health & Safety

- a) THE HIRER shall, if preparing, serving or selling food, observe all relevant health and hygiene legislation and regulations. Hirers must follow the instructions provided for the use of all equipment, especially in the kitchen.
- b) THE HIRER shall ensure that any electrical or other appliances brought by him/her to the premises and used there shall be safe and in good working order, and used in a safe manner.
- c) HIRERS need to be aware that the *external door of the kitchen should be unlocked whilst the hall is in use*, as it is a fire exit. A key can be found on the door. A key for opening the windows, and for the dishwasher drawer should they be required can be found in the fridge. It is the Hirer's responsibility to ensure this external door is locked and the key returned on vacating the hall.
- d) Please note that the use of gas cylinders is prohibited throughout the building.
- e) THE HIRER and/or other responsible persons present should be aware of the location of the first aid kit which can be found on the wall at the back of the hall to left of the kitchen hatch. There is also a first aid kit in the upper hall, in the cupboard below the sink.
- f) The HIRER should also be aware of the fire fighting equipment and the procedures for emergency evacuation of the premises, (these are clearly displayed at several points in the Hall). Hirers are reminded that they are responsible for any accident or injury arising out of the activity for which they have booked the premises. It is the responsibility of the Hirer to ensure that the premises are safe for the purposes for which they intend to use them.
- g) HIRERS of St Paul's Church Hall are required to complete details of any accident or incident occurring during their occupation of the premises which did or could give rise to injury as soon as possible after the accident or incident but in any case before the premises are vacated by the hirers after the event. A book is provided for this purpose and this is located on the Health and Safety notice board.

Hirers of the upper hall should note the information and report the accident to the church office.

The following information should be recorded:

- a) Name, address and telephone number of person(s) injured
- b) Exact time and place of the occurrence
- c) Detailed description of accident or incident, including a description of any apparatus or equipment involved
- d) Name, address and telephone number of any witness(es) to the accident
- e) Signed witness statements should be obtained if possible.
- h) THE HIRER must notify the church office as soon as possible after the accident, but in any event within 24 hours. The tear out slip is required to be held in the church office. Any apparatus or equipment involved must be retained for inspection.
- i) Smoking is not allowed in any part of the premises.
- j) Should there be a need to evacuate the premises. Please sound the air horns. One is located by the kitchen door in the main hall, and the other by the main door of the upper hall (they are clearly labelled). Please sound even if you believe everyone is out, as there may be people in other areas of the building you are not aware of.

5. Conditions for Use

- a) THE HIRER shall not use the premises for any purpose other than that described in the hiring agreement and shall not sub-hire or use the premises or allow the premises to be used for any unlawful purpose or in any unlawful way, nor do or bring on to the premises anything which might endanger the same or render any insurance policies in respect thereof.

- b) THE HIRER should ensure that if their event includes any act of religious worship, it must be agreed in advance with the church.
- c) The HIRER is responsible for collecting keys (usually on the morning of hire, or on preceeding Friday for a weekend booking. When keys are not collected during office hours and an alternative is arranged, a £20 fee will be payable.
- d) THE HIRER shall repay St Paul's Church Letchworth PCC for the cost of repair of any damage done during the period of the hiring as a result of the hire. Where the cost of the damage exceeds the deposit, the deposit will be retained and any excess will be invoiced to the Hirer.
- e) THE HIRER shall ensure that the minimum of noise is made on arrival and departure.
- f) HIRERS of the Hall are responsible for safeguarding their own personal effects or other property and all such items brought into the Hall shall be placed and/or used there entirely at the owner's risk.
- g) All equipment, goods or appliances brought into the Hall for use during the period of hire shall be removed at the end of that period, unless prior arrangements to the contrary have been made.
- h) Should additional chairs be required this should be noted on the booking form and brought to the attention of the booking secretary. It is the responsibility of THE HIRER to remove them from their temporary location and return them in the specified manner.
- i) Temporary decorations shall only be erected using blutack. No decorations should be fixed in any other way to any part of St Paul's Church Letchworth PCC's property without prior consent being obtained.
- j) Hirers must ensure that especially during good weather, guests stay inside the hall and do not move into the car park, in respect of our neighbours.
- k) Hirers are not permitted the use of fireworks or sky lanterns either in the hall or the car park.

- l) Persons authorised by St Paul's Church Letchworth PCC shall have the right of entry to the premises at all times.
- m) Details of the insurance held covering the Church Hall are available on request from the Booking Secretary.
- n) Any issues with the hire such as individual lights not working, cleanliness of hall and facilities etc should be reported to the booking secretary as soon as possible, but definitely within 48 hours. This can be done on 01462 637373 or hello@stpaulslethworth.co.uk.
- o) At the end of the hire, THE HIRER
 - shall be responsible for leaving the premises and surrounds in a clean and tidy condition - there is a kitchen cleaning kit under the sink for your use and mop, bucket and brushes in Gents Toilet. Hirers must remove any items they have left in the fridge at the end of the hiring and ensure the gas cooker is turned off.
 - must ensure that all refuse resulting from the hire shall be removed from the premises. If you have a large amount of rubbish please take it away and dispose of it yourself. Small amounts may be put into the appropriate bins outside the hall.
 1. Grey recycling bin: mixed plastic, glass, tin and cardboard.
 2. Brown bin: garden and food waste.
 3. Grey Trade bins x2: general waste.
 4. Purple bin: general waste.
 - shall ensure that all doors and windows are properly locked and secured unless directed otherwise, and any contents temporarily removed from their usual positions are properly replaced, otherwise St Paul's Church Letchworth PCC may retain the deposit in full or in part. The keys should be returned via the post box on the front of the Main Hall.

- Changes should not be made to the thermostat or heating systems. If there is an urgent problem with the heating, please call the out of hours contacts.
- Shall ensure that all toilets are vacated

6. Parking

There are a few parking spaces located in front of the Church Hall. There are many more around the church itself. Care should be taken to observe allowance for disabled drivers and also the operation of a one way system. Entry should be via Baldock Road and exit into Pixmore Way. Please avoid parking in Pixmore Way where possible.

St Paul's Church Letchworth PCC cannot guarantee the provision of parking for hall users especially when this coincides with other events in the other hall or church.

7. Public Entertainment

The Hall is licensed for public entertainment consisting of music and/or singing, and/or dancing under the *Licensing Act 2003* by North Herts District Council. Full details of the conditions attached to the licence can be obtained on request, but those that may have a direct effect on the Hirer include:

- No fly posting of events
- Music provided at the premises shall not cause a public or statutory nuisance.

8. Safeguarding

The Parochial Church Council of St Paul's has Policies in place for Safeguarding Children, Young People and Vulnerable Adults. These are available on our website

www.stpaulsletchworth.co.uk/safeguarding. Your booking agreement is conditional upon you complying with our policies unless you already have an equivalent policy of your own.

THE HIRER is required to ensure that children, young people and vulnerable adults are protected at all times, by taking all

reasonable steps to prevent injury, illness, loss or damage occurring; and that you carry full liability insurance for this.

In particular this means that:

- THE HIRER will familiarise themselves with our Safeguarding Policies from our website.
- THE HIRER will comply with our policies in relation to children and young people or vulnerable adults and make sure your staff and leaders of the activities on our premises are fully aware of their requirements. Unless you already have an equivalent;
- THE HIRER will provide the church with a copy of your organisation's Safeguarding Policy/ies or if you do not have one adopt the current parish policy;
- THE HIRER will recruit safely all current paid and voluntary workers who work with children and/or vulnerable adults, by obtaining satisfactory disclosures from the Disclosure and Barring Service where eligible, and keeping records of dates and disclosure numbers indefinitely;
- THE HIRER will keep a list of the names of all paid and voluntary workers with regular and direct contact with children/vulnerable adults, and update it annually;
- THE HIRER will always have at least two leaders over the age of 18 years in any group of children and young people, no matter how small the group;
- THE HIRER will ensure no one under the age of 18 years will be left in charge of any children or young people of any age;
- THE HIRER will ensure no child or group of children or young people should be left unattended at any time;
- a register of children, young people or vulnerable adults attending the activity will be kept securely. This will include details of their name, contact details of parent/guardian/carer etc., date of birth and next of kin;

- you will immediately (within 24 hours) inform the Parish Safeguarding Officer of:
- (a) the occurrence of any incidents or allegations of abuse or causes of concern relating to members or leaders of your organisation, and contact details for the person in your organisation who is dealing with it
- (b) any known offenders against children or vulnerable adults seeking to join your membership, and manage such allegations or agreements with offenders in co-operation with statutory agencies, and with the church.

The Parish Safeguarding Officer for St Paul's Church can always be contacted via email at Safeguarding@stpaulslethworth.co.uk

Further contact details and our Safeguarding Policies are available on our website at www.stpaulslethworth.co.uk/safeguarding

9. General

Notwithstanding anything contained in their Terms and Conditions, St Paul's Church Letchworth PCC will not be liable for any failure to perform its obligations to the Hirer in whole or part as a result of any of the following.

- a) Failure of supply of electricity or gas
- b) Strikes
- c) Other industrial action
- d) Fire at or near the premises
- e) Leakage of water, or flood at or near the premises
- f) Civil unrest, dispute or commotion
- g) Act of God
- h) Legal action against St Paul's Letchworth PCC not resulting from its negligence preventing the supply of services.